

INSTALLATION AND OPERATING INSTRUCTIONS FOR GAS VALVE INTERLOCK CONTROL PANEL GVI-001

Specification

Model no.	Electrical supply	Current Rating	Dimensions (H x W x D)	Mounting
GVI-001	230v 1Ph 50Hz	As marked	87mm x 147mm x 46mm	Surface

Control panel connections

- Electrical supply: 230v 1Ph 50Hz
- Remote emergency stop button
- Pressure or current switch for supply airflow proving
- Pressure or current switch for extract airflow proving
- Gas valve solenoid: 230v 1Ph 50Hz

Control panel features

- Airflow off lamp
- Airflow on lamp
- Keyswitch for normal/gas off
- 10 second overrun timer to overcome loss of supply to gas valve actuator in case of backdrafts



Installation

Install in a dry sheltered position. Do not install in close proximity to a heat source.

Remove the front cover of the controller by unscrewing the fascia fixing screws. This provides access to mounting holes and electrical terminals. All wiring must be carried out by a suitably qualified and competent person and comply with current applicable regulations.

Operation

The GVI-001 is a gas valve interlock control system that has connections for either pressure switches or current switches to prove airflow and when that airflow is proved then the electrical supply to the gas valve solenoid is enabled.

Pressure switches

When using the GVI-001 with pressure switches then the pressure switches are wired to the panel using the normally open contacts, which close when there is airflow present. The pressure switches are required to have closed contacts (airflow present) for the electrical supply to the gas valve solenoid to be enabled. If only extract airflow is monitored then a link between terminals 5 & 6 is to be fitted.

Current switches

When using the GVI-001 with current switches then these current switches are wired to the panel using the pair of thin cables on the current switches. If only extract airflow is monitored then a link between terminals 5 & 6 is to be fitted.

When airflow is proved the airflow on lamp will light and the electrical supply to the gas valve solenoid will be enabled. When there is a loss of airflow the gas valve solenoid will remain enabled for 10 seconds. This is to prevent loss of gas in the event of backdrafts.

Remote emergency stop button connections

The GVI-001 has connections to allow the fitting of a remote emergency stop button if required. When this is activated the electrical supply to the gas valve solenoid will be disabled.

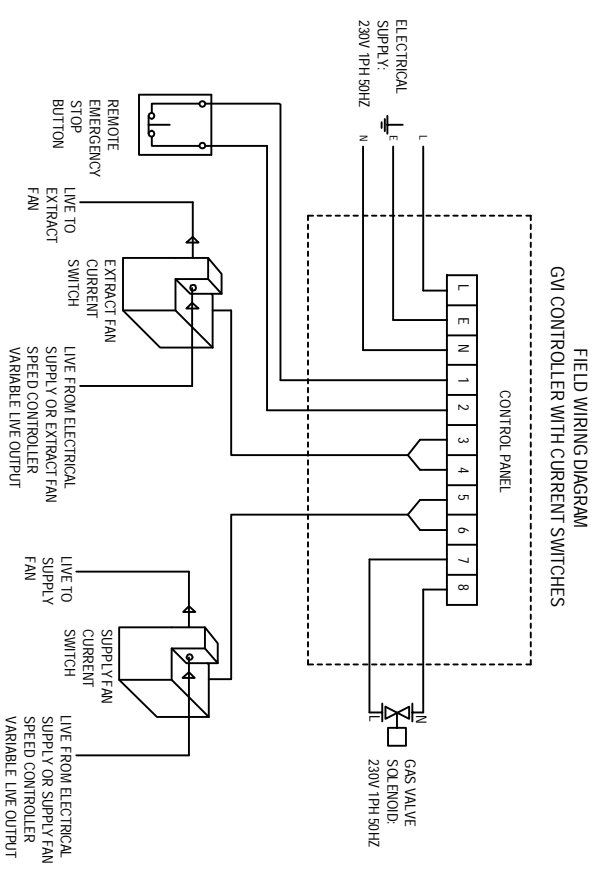
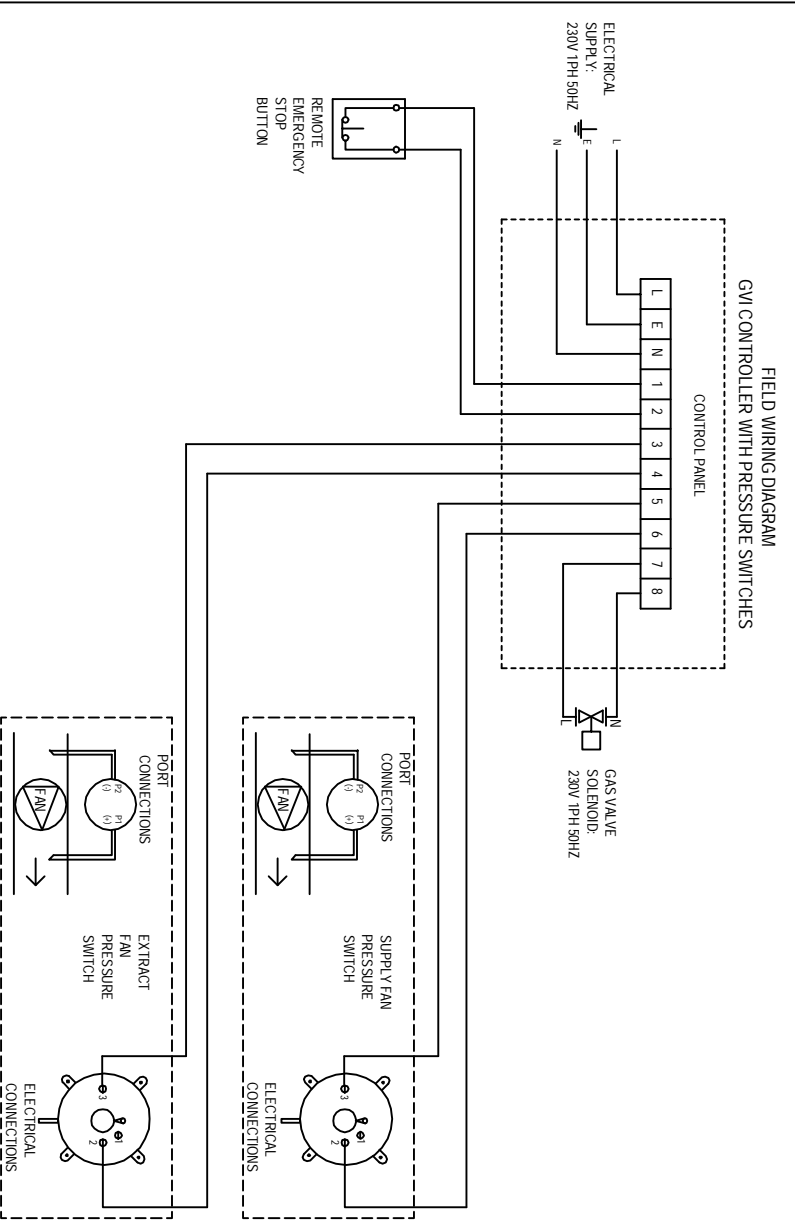

Notes

If there is no emergency stop button fitted then fit a link between terminals 1 & 2 on the GVI controller.

If there is no pressure switch or current switch fitted to monitor the supply fan then fit a link between terminals 5 & 6 on the GVI controller.

When using the current switch:

The extract fan current switch is connected to terminals 3 & 4 on the GVI controller
 The supply fan current switch is connected to terminals 5 & 6 on the GVI controller

Connect the brown wire to terminal 3 (extract fan current switch) and terminal 5 (supply fan current switch) of the GVI controller.

Connect the yellow wire to terminal 4 (extract fan current switch) and terminal 6 (supply fan current switch) of the GVI controller.