



Features & Benefits

- Wide range of sensor types
- Choice of output type and temperature ranges on one unit
- Custom output range scaling

Technical Overview

The -CVO active output option combines 4 pre-set ranges and selectable output mode, customised output range scaling enabling a choice of outputs and ranges on one unit.

Product Codes

Sensor Type:

TT-518	Thimble Sensor
TT-322	Duct Sensor
TT-325	Duct Averaging Sensor
TT-626	True Duct Averaging Sensor
TT-331	Outside Air Sensor
TT-332	Outside Air Sensor c/w Radiation Shield
TT-341	Immersion Sensor
TT-342	High Temp. Immersion Sensor
TT-351	Clamp-on Sensor
TT-359	Direct Clamp-on Sensor
TT-554	Remote Probe Sensor
TT-555	Flying Lead Sensor

(add type to above code):

-CVO	4-20mA/0-10Vdc selectable output
-CVO-C	4-20mA/0-10Vdc selectable output with custom temp. scaling

Specification

Selectable output type:

0-10Vdc
4-20mA (loop powered)

Selectable output range:*

-10 to +40°C -10 to +110°C
-10 to +160°C 0 to +400°C

Custom range:*

-40 to +400°C

Supply voltage:

0-10Vdc 24Vac ±15% @ 50Hz *or*
24Vdc +15% -6%
4-20mA 24Vdc +15% -6%

Accuracy:

TT-626 only	
Transmitter	±0.2°C
PRT Element	±0.425°C @ 25°C
Overall	±1.0°C

Others

Transmitter	±0.2°C
PRT Element	±0.2°C @ 25°C
Overall	±0.4°C

Sensor type:

TT-626 only	PT100B
Others	D (PT100A)

Connectors

Terminals for 0.5-2.5mm² cable

Ambient range:

Temperature -10 to 50°C
Humidity 0 to 80%RH, non-condensing

Country of origin

UK

* Dependent on sensor type

Note:

Please see corresponding temperature datasheet for further specification and full installation instructions.

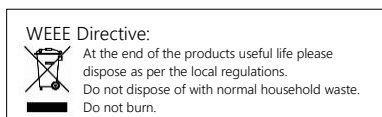

The products referred to in this data sheet meet the requirements of EU Directive 2014/30/EU

Connections



Antistatic precautions must be observed when handling these sensors. The PCB contains circuitry that can be damaged by static discharge.

4-20mA output:

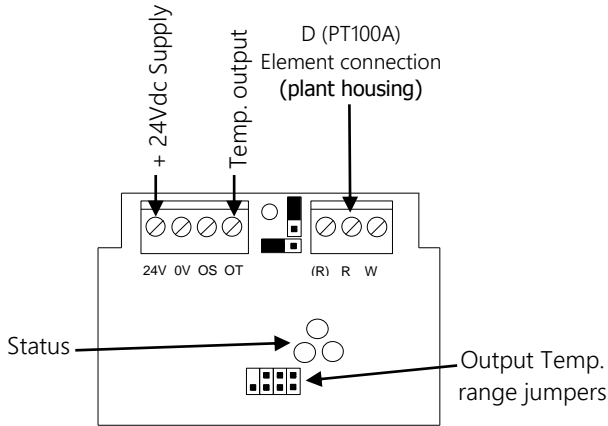

Voltage output Nominal voltage 24Vac/dc.

Current output If using in current output mode, the sensor must only be used with a 24Vdc supply. The sensor may be damaged if supplied with AC.

The selectable output temperature ranges are dependent on sensor type, ambient and application.

0-10Vdc output:

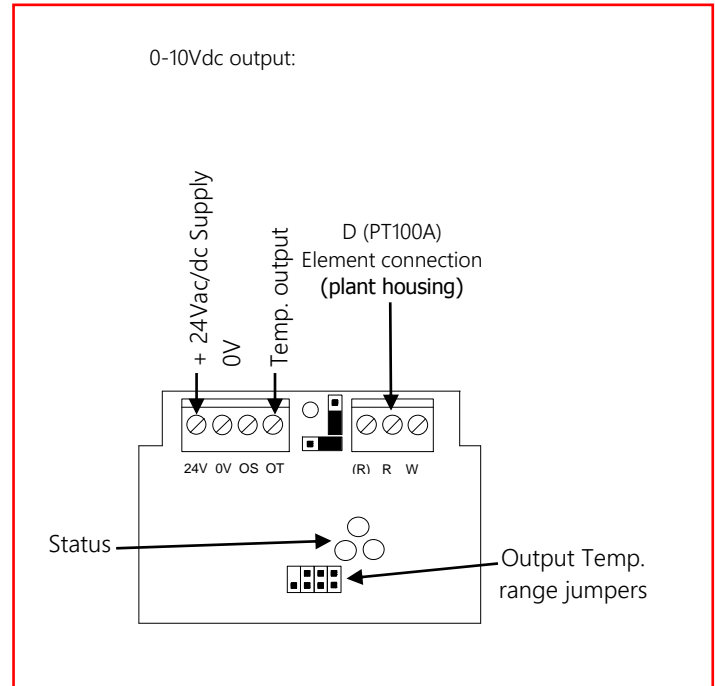

Jumper Settings

Output temperature range section:

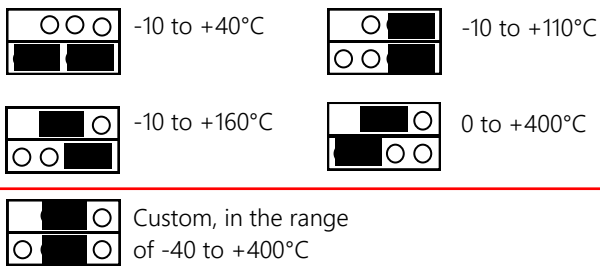

Output signal type:



If the range links are incorrectly set, or missing the output range Will default to -10 to +40°C

Factory default jumper positions

- Temperature range -10 to +40°C
- Output signal 0-10Vdc

LED Status

Power supply

Normal:

The green LED indicates the supply condition. If the power supply is normal the green LED is ON continuously. This shows that the TT-CVO is powered correctly.

Low Supply Voltage:

If power supply falls below about 22V the green LED does double flashes twice a second;

*_*_*_*_*_*_*_*_*_*_*_*_*_*_*_**

The PCB tries to maintain the correct output but may be unable to achieve the specified voltage or current level. At very low voltages it will stop working.

High Supply Voltage:

If the power supply is above 40V the green LED flashes 6 times a second;

*_*_*_*_*_*_*_*_**

The PCB tries to maintain the correct outputs but components on the PCB may overheat causing unreliability and ultimately failure.

Output

4-20mA output:

The red LED is on when the PCB is in 4-20mA mode and working correctly. For this to be so these conditions must be met:

- The output select jumper(s) must be set to the 4-20mA position.
- The output load must be an impedance of 500Ω or less.
- The PCB is capable of sourcing the correct output current. (The red LED may flash if the PSU is below 22V or the impedance is more than 500Ω).
- If using a current output mode, the sensor must only be used with a 24Vdc supply. The sensor may be damaged if supplied with AC.

0-10Vdc output:

The output select jumper(s) must be connected in the 0-10Vdc position, minimum impedance 2kΩ.

Whilst every effort has been made to ensure the accuracy of this specification, Sontay cannot accept responsibility for damage, injury, loss or expense from errors or omissions. In the interest of technical improvement, this specification may be altered without notice.